

TAPSA – EMERGENCY LIGHTING CENTRAL BATTERY UNIT

TK2301 – TK2308

Installation and maintenance instructions

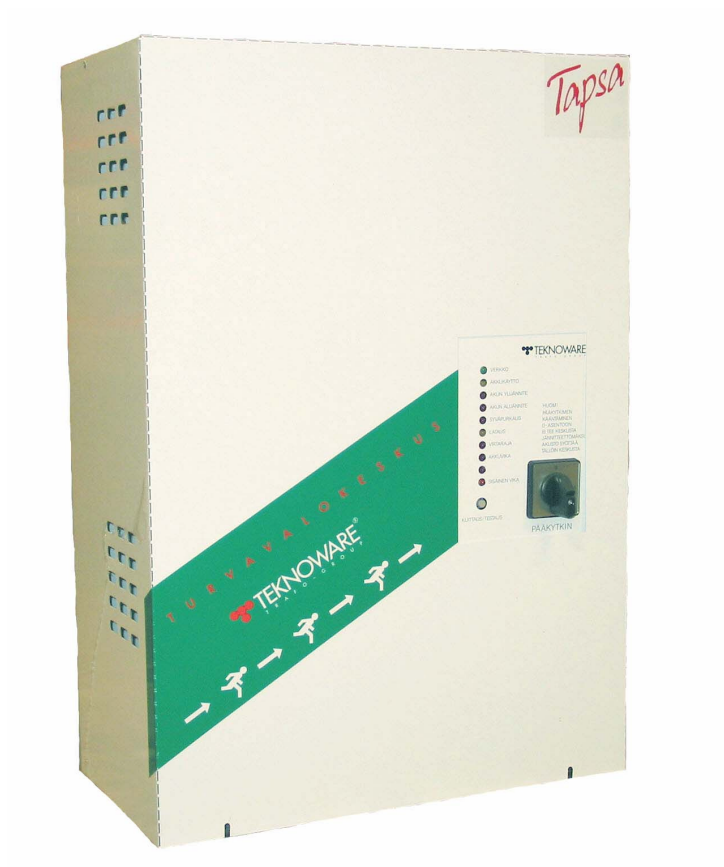

KEEP IN A SAFE PLACE FOR LATER USE

Table of Contents	Page
1. Description	3
1.1. Manufacturer	3
1.2. Type code	3
1.3. General description	3
1.4. Technical data	3
1.5. Directives and standards applied	4
2. Operational description	4
2.1. Outputs	4
2.2. Recharging of the batteries	4
2.3. Limits of the mains voltage	4
2.4. Limits of the battery voltage	5
2.5. Alarm relay outputs	5
3. Installation of the system	5
4. Commissioning	6
4.1. Setting the charging current	6
5. Maintenance	6
5.1 Maintenance procedures	7
5.2. Replacing the batteries	7
6. Disposal	7

Appendixes:

Appendix 1.	Control panel
Appendix 2.	Block diagram
Appendix 3.	Mechanical dimensions
Appendix 4.	Component layout
Appendix 5.	External connection



1. Description

1.1. Manufacturer

Teknoware Oy
Ilmarisentie 8
FIN-15200 Lahti
FINLAND

1.2. Type Code

TK2301 ... TK2308 (See point 1.4. Technical data)

1.3. General description

Tapsa central battery unit is based on Teknoware's modular Tapsa –central battery unit family for emergency lighting. In normal conditions the central unit takes its power from the 230VAC mains supply recharging the batteries and supplying the maintained luminaire groups with 230VAC voltage. In the case when the mains supply disappears or drops below 180VAC, the unit switches itself to emergency mode. Then the supply is taken from the 24VDC batteries and converted to 230VDC, which is supplied to both maintained and non-maintained luminaire groups. The supply is taken from the batteries as long as the net supply remains down or until the battery voltage drops to the deep discharge protection level of 19,2V.

All operations regarding the usage of the central unit can be performed from the control panel of it. Control panel has also LEDs for the indication of the status of the central unit. The operations of the panel are described in the appendix 1.

1.4. Technical Data

Mains connection: 230VAC 50Hz 1~
Output voltage: normal mode: 230VAC, emergency mode: 230VDC
Battery voltage: 24VDC
Battery charging time: 12h
Ambient temperature range: +10 ... +30°C
Input fuse: 5x20mm glass tube 10A
Group fuses: 5x20mm glass tube 630mA (output) and 10A glass tube 24VDC (input)
Battery fuse TK2301-TK2302: 16A 2-pole circuit breaker QY, curve U2 S 16A/80VDC CBI
Battery fuse TK2303-TK2305: 35A 2-pole circuit breaker QY, curve U2 S 35A/80VDC CBI
Battery fuse TK2306-TK2308: 60A 2-pole circuit breaker QY, curve U2 S 60A/80VDC CBI

Charging circuit fuses: Blade type fuse 15A

Type of the central unit	Input power from the main supply	Outputs	Total load capacity with 1h and 3h duration	Battery capacity with 1h and 3h duration
TK2301	370 VA	1 x 120 W	1h 120W / 3h 120W	2x17Ah / 2x38Ah
TK2302	490 VA	2 x 120 W	1h 220W / 3h 220W	2x24Ah / 2x65Ah
TK2303	610 VA	3 x 120 W	1h 360W / 3h 360W	2x38Ah / 2x100Ah
TK2304	730 VA	4 x 120 W	1h 480W / 3h 480W	2x65Ah / 2x100Ah
TK2305	850 VA	5 x 120 W	1h 600W / 3h 480W	2x65Ah / 2x100Ah
TK2306	970 VA	6 x 120 W	1h 720W / 3h 480W	2x65Ah / 2x100Ah
TK2307	1090 VA	7 x 120 W	1h 840W / 3h 480W	2x100Ah / 2x100Ah
TK2308	1210 VA	8 x 120 W	1h 960W / 3h 480W	2x100Ah / 2x100Ah

The central unit is fitted with a mains voltage fuse F2 10AT (inside the unit TS1), battery fuse F1 and recharging circuit fuse F1 and F2 (on the charger unit TS2). The battery recharge electronics is fitted with a battery temperature sensor, which controls the temperature compensation of the recharging voltage.

The luminaries which are used with the central unit shall be suitable for both AC- and DC-supply.



Teknoware Oy, Ilmarisentie 8, FI-15200 LAHTI, FINLAND. Tel. +358 3 883 020, fax +358 3 883 0260
www.teknoware.fi e-mail: emexit@teknoware.fi

1.5. Directives and standards

The following directives and standards were applied in designing and manufacturing the unit:

EN 50171:2001	Central power supply systems	
EN 50081:1992	Electromagnetic compatibility. Residential, commercial and light industry, generic emission standard	
EN 50082-1:1997	Electromagnetic compatibility. Generic immunity standard. Residential, commercial and light industry.	
Electrical safety and performance:	72/23/EEC, 93/68/EEC EN 50171:2001	Low voltage directive Central power supply systems
Electro magnetic compatibility:	89/336/EEC, 92/31/EEC EN 50081:1992 EN 50082-1:1997	EMC-directive Residential, commercial and light industry, generic emission standard Electromagnetic compatibility, generic immunity standard. Residential, commercial and light industry.

2. Functional description

In normal mode, the unit task is to monitor mains voltage and to charge batteries as well as to feed the maintained output groups. During a power failure, the unit feeds the maintained and non-maintained output groups with the energy stored in the batteries.

Explanations of signal LEDs and buttons are available in Appendix 1.

2.1. Outputs

The output of the Tapsa-Control central unit is divided to max 8 groups. Each of them can be connected to maintained or non-maintained operation by the "Mode" –connectors as follows:

"Mode" –connection closed: maintained
"Mode" –connection open: non-maintained

2.2. Recharging of the batteries

After the mains voltage breakdown the batteries are first recharged with a constant current (0.1c) until the voltage reaches 28.8V. After this there is a cyclic charge period where the recharging voltage is changed between 28.8V and 27.0V in the cycles of 4 minutes. These recharging modes last totally 12 hours after which the recharging is continued in a trickle charge mode where the battery voltage is maintained in 27.0V.

*Display: Mains use -LED is on
Recharging -LED is on when the battery voltage is 27V±0.3V, otherwise it is blinking*

2.3. Limits of the mains voltage

When the mains voltage decreases below 180V (still being over 100V), the central unit turns to emergency mode showing the following display.



*Display: Mains use –LED is blinking
Emergency mode -LED is on*

When the mains voltage drops below 100 V, the central unit turns to emergency mode showing the following display.

Display: Emergency mode -LED is on

When the mains voltage returns or increases to over 195V, the central turns unit back to normal mode and recharges the batteries as described in the point 2.1.3.

*Display: Mains use -LED is on
Recharging -LED is on when the battery voltage is $27V \pm 0.3V$, otherwise it is blinking*

2.4. Limits of the battery voltage

If the battery voltage increases to over 28.8V in normal mode, there is an overvoltage alarm given.

*Display: Mains use -LED is on
Over voltage -LED is on
Recharging –LED is blinking
Internal fault –LED is on*

If the battery voltage drops under 25.2V in normal mode, there is an undervoltage alarm given.

*Display: Mains use -LED is on
Under voltage -LED is on
Recharging -LED is blinking
Internal fault –LED is on*

When the central unit is in emergency mode and the battery voltage decreases below 19.2V, the central unit turns to deep discharge protection mode where the discharging of the batteries is discontinued.

*Display: Deep discharge -LED is on
Internal fault -LED is on*

Deep discharge –LED remains on until it is reset from the *reset/test* push-button switch.

The central unit can be manually switched to emergency mode also by a remote control switch, if it is fitted.

*Display: Mains use -LED is blinking
Emergency mode -LED is on*

If the battery is disconnected or it does not accept recharge current, there are the following alarms on the display:

*Display: Mains use -LED is on
Battery fault -LED is on
General fault -LED is on*

2.5. Alarm relay outputs

Internal fault alarm - Gives an alarm when an internal fault has been detected.
Operation alarm - Gives an alarm when the central unit is in emergency mode.

3. Installation of the system

Only a skilled person may perform operations related to installation, initial settings and maintenance of the system.



System installation takes place according to the electrical design plan or the electrical work explanation.

Before beginning of the installation, the mains switch and battery fuse of the central shall be set to 0-position. The batteries are installed inside the central or in the separate battery container and they are connected in series (2x12V) to the battery cables + and -. The temperature sensor of the batteries shall be located so that it is close to the surface of them, preferably between the batteries. Double-check the correct polarity of the batteries before connection. Connect the mains supply to the connectors L, PE and N. Next connect the maintained and non-maintained groups (see appendix 4, external wiring). The output groups are connected from the "Mode" connectors (see appendix 5, external connection) as maintained or non-maintained groups as follows.

"Mode" –connection closed: maintained group

"Mode" –connection open: non-maintained group

The wiring of remote alarm and remote control switch is connected if they are included to the installation.

4. Implementation

Only a skilled person may perform operations related to installation, initial settings and maintenance of the system.

Each central and luminaries are tested for electrical safety according to the Low Voltage Directive by manufacturer. If there is an insulation resistance test made for the external wiring of the system, the input and outputs of the Tapsa central shall be short-circuited.

When the necessary installations and inspections are made, turn the battery fuse F1 to position 1 and turn the main switch S1 position 1.

*Display: "Recharging" –LED is blinking
"Mains use" –LED is on*

4.1. Setting the charging current

Charging current is set to minimum value as the factory setting.

During commissioning the charging current shall be set as follows:

Set the current from the DIP -switch of the charging module TS2 (see appendix 4). The charging current shall be always set according to the ampere hour value (Ah) of the batteries. If the value is incorrectly set, the batteries may get damaged. When all the switches are in OFF -position, the charging current is set for 100Ah batteries.

DIP SWITCH SETTING TS2	Battery capacity
1 DIP ON	17Ah
2 DIP ON	24Ah
3 DIP ON	38Ah
4 DIP ON	65Ah
ALL OFF	100Ah

Note: only one DIP switch may be "ON" at the same time.

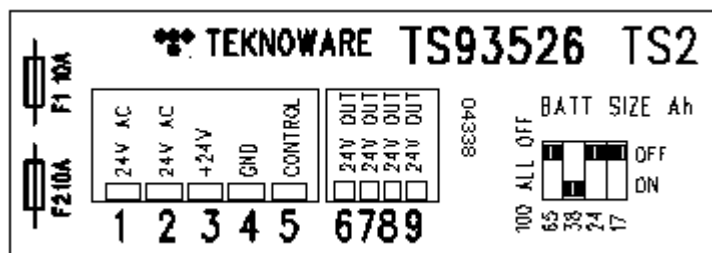

Teknoware Oy, Ilmarisentie 8, FI-15200 LAHTI, FINLAND. Tel. +358 3 883 020, fax +358 3 883 0260
www.teknoware.fi e-mail: emexit@teknoware.fi

ATTENTION! SET THE CURRENT ALWAYS WITH THE VOLTAGE DISCONNECTED

Mark the total load and battery mode duration to the type label which is located inside the panel.

5. Maintenance

Only a skilled person may perform such maintenance operations which require opening the casing of the central or the battery container.

5.1. Maintenance procedures to be performed according to the EN 50172 standard

- Daily checking that maintained luminaires are functioning
- Daily checking that the front panel indicators of the central battery unit are ok.
- Monthly checking that all luminaires operate on battery mode
- Annual full battery duration test
- Tests and inspections made must be recorded in the emergency lighting system maintenance manual which shall be shown to the authorities when requested

5.2. Replacing the batteries

The batteries are replaced as follows:

- Remove the cover of the central unit
- Turn the battery fuse switch F1 to position 0
- Turn the main switch S1 to position 0 (the display turns off= Central Battery unit has no voltage)
- Remove the battery casing lid (if it is in use)
- Disconnect the battery cables
- Remove the batteries and install new ones
- Place the temperature sensor of the batteries between the batteries
- Connect the battery cables (*double-check the polarity and insulation distances*)
- Install the cover of the battery container (if it is in use)
- Turn the battery fuse switch F1 to position 1
- Install the cover of the central
- Turn the main switch S1 to position 1

8. Disposal

When removing the central system and its components from usage, note the following points in the destruction of them:

Batteries and fluorescent lamps are hazardous waste. Metal parts shall be recycled as steel or aluminium waste. Wires, connectors and circuit boards are considered as electronics waste. Plastic parts shall be recycled according to the material markings of them.



APPENDIX 1

Control panel:

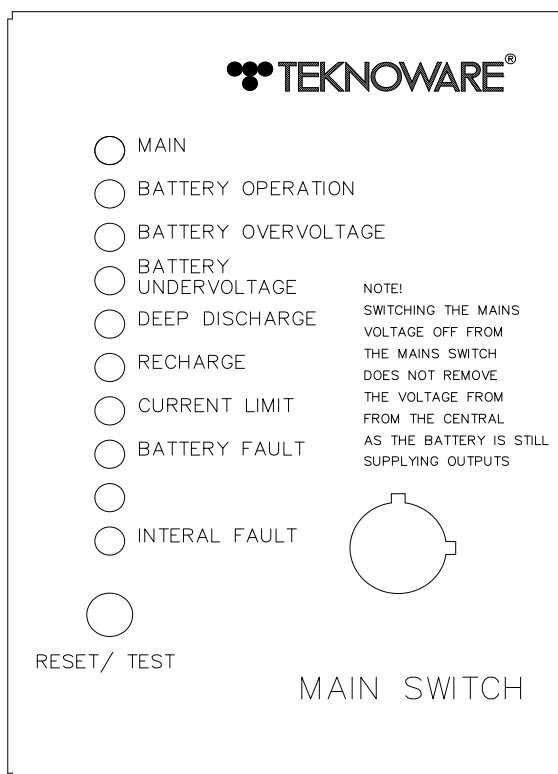

Descriptions of the indication LEDs:

Indication LED:	Description:
MAIN	- The central is operating in normal mode from the mains supply. - If the LED blinks, the mains voltage is 100V-180V or the central is switched to emergency mode from the remote control switch or the control-module is currently performing the automating test.
BATTERY OPERATION	- The central is in emergency mode running on the battery power
BATTERY OVERVOLTAGE	- Battery voltage is higher than normally (over 28.8V)
BATTERY UNDERVOLTAGE	- Battery voltage is lower than normally (under 25,2V)
DEEP DISCHARGE	- The deep discharge protection of the battery has operated (the voltage has dropped in emergency mode below 19.2V)
RECHARGE	- Indicates that the recharging voltage of the battery is on, and it is at correct level (27,0V +-0,3V) - When the LED is blinking, the Central unit is boost-charging - When the LED is lit continuously, the Central Battery unit is in maintenance charge
CURRENT LIMIT	- Indicates too high recharging current
BATTERY FAULT	- Indicates the condition of the battery and battery circuit
INTERNAL FAULT	- General fault indication. Operates if the battery over voltage, battery under voltage, deep discharge protection, current limit, battery fault or ground leakage LED is operating.

Push-buttons

RESET / TEST	Resetting of the deep discharge protection alarm / starting of the 8 minutes emergency mode test
--------------	--



Teknoware Oy, Ilmarisentie 8, FI-15200 LAHTI, FINLAND. Tel. +358 3 883 020, fax +358 3 883 0260
www.teknoware.fi e-mail: emexit@teknoware.fi

APPENDIX 2

Schematic diagram

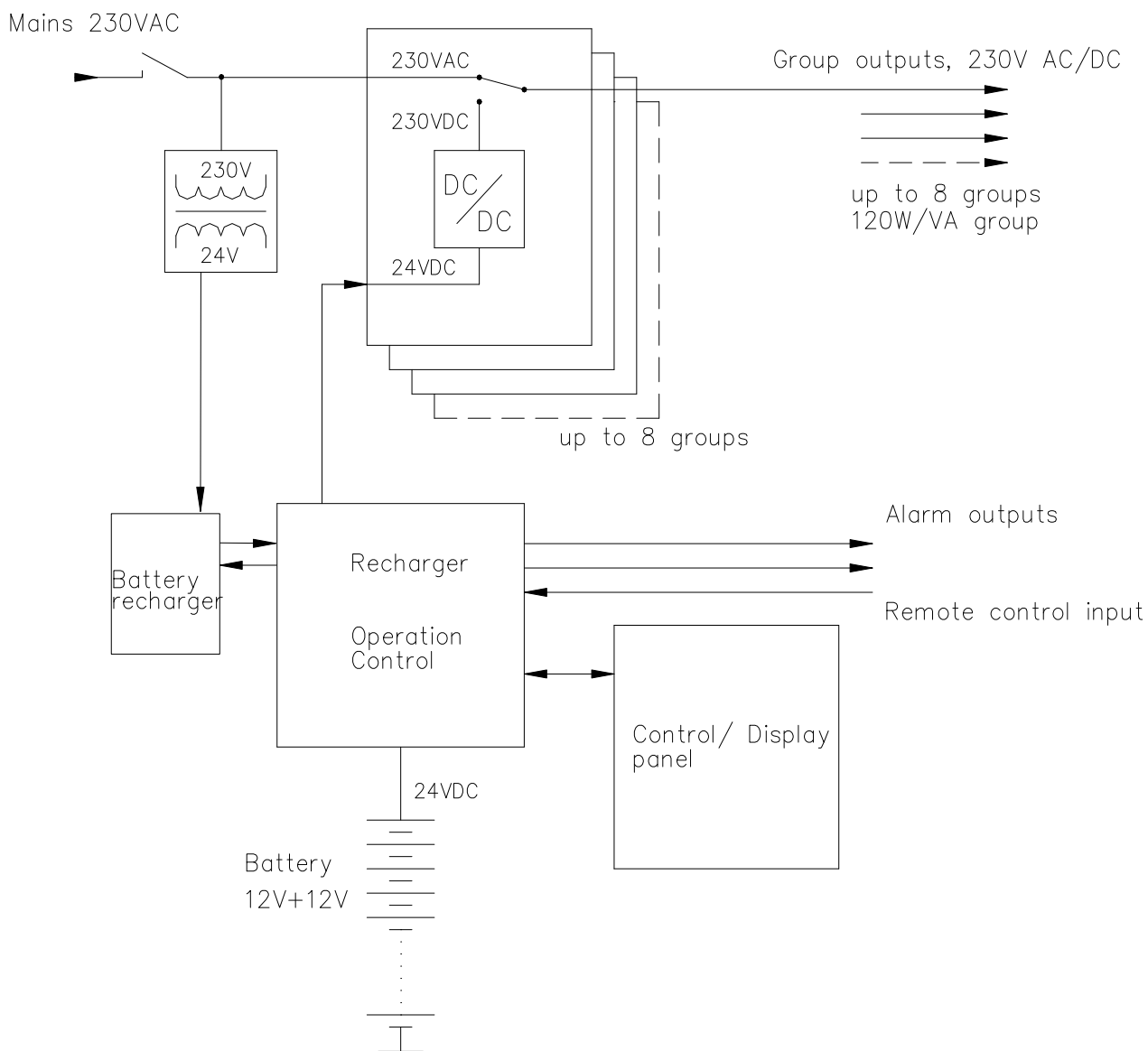

Teknoware Oy, Ilmarisentie 8, FI-15200 LAHTI, FINLAND. Tel. +358 3 883 020, fax +358 3 883 0260
 www.teknoware.fi e-mail: emexit@teknoware.fi

APPENDIX 3

Mechanical measurements

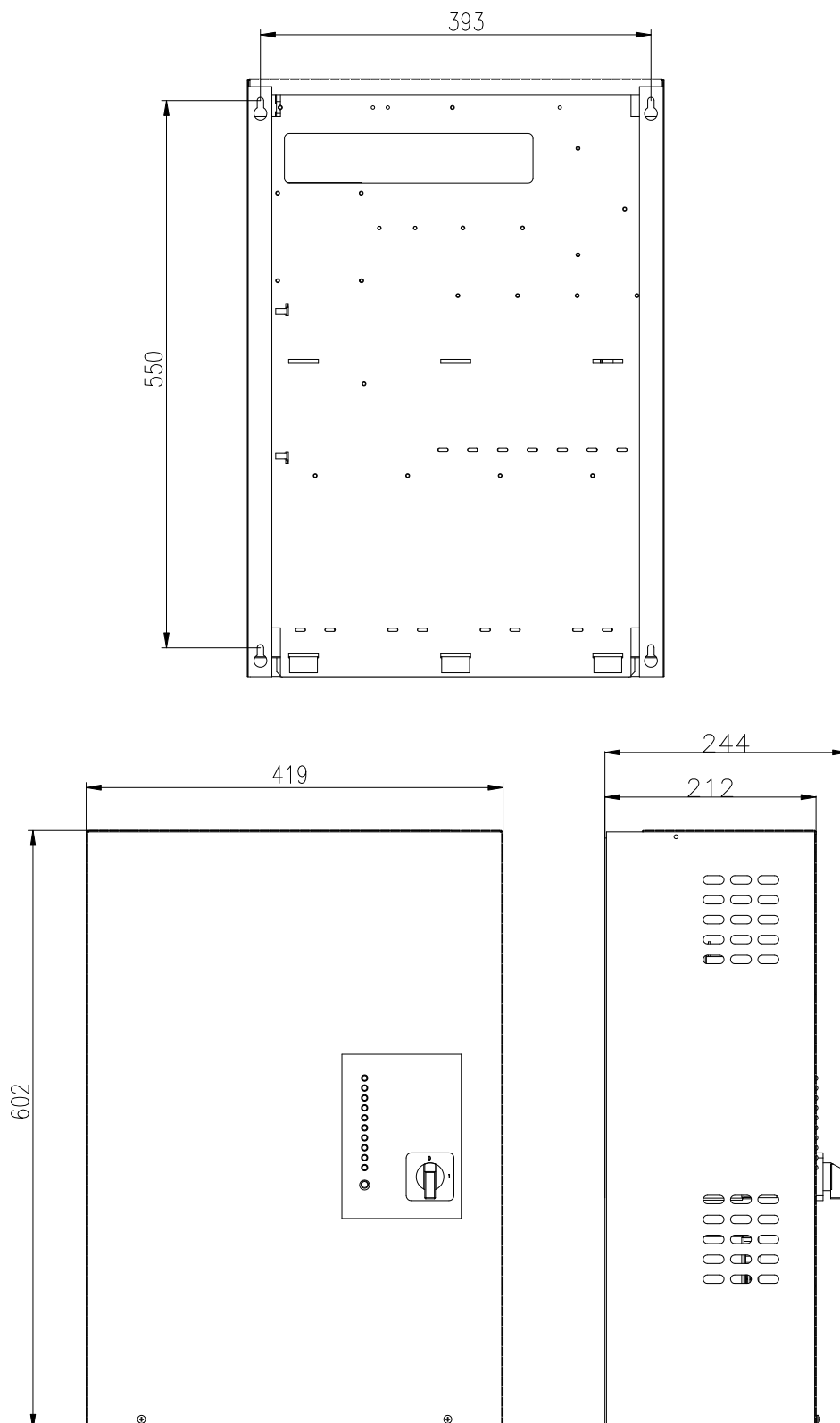

APPENDIX 4

Part placement

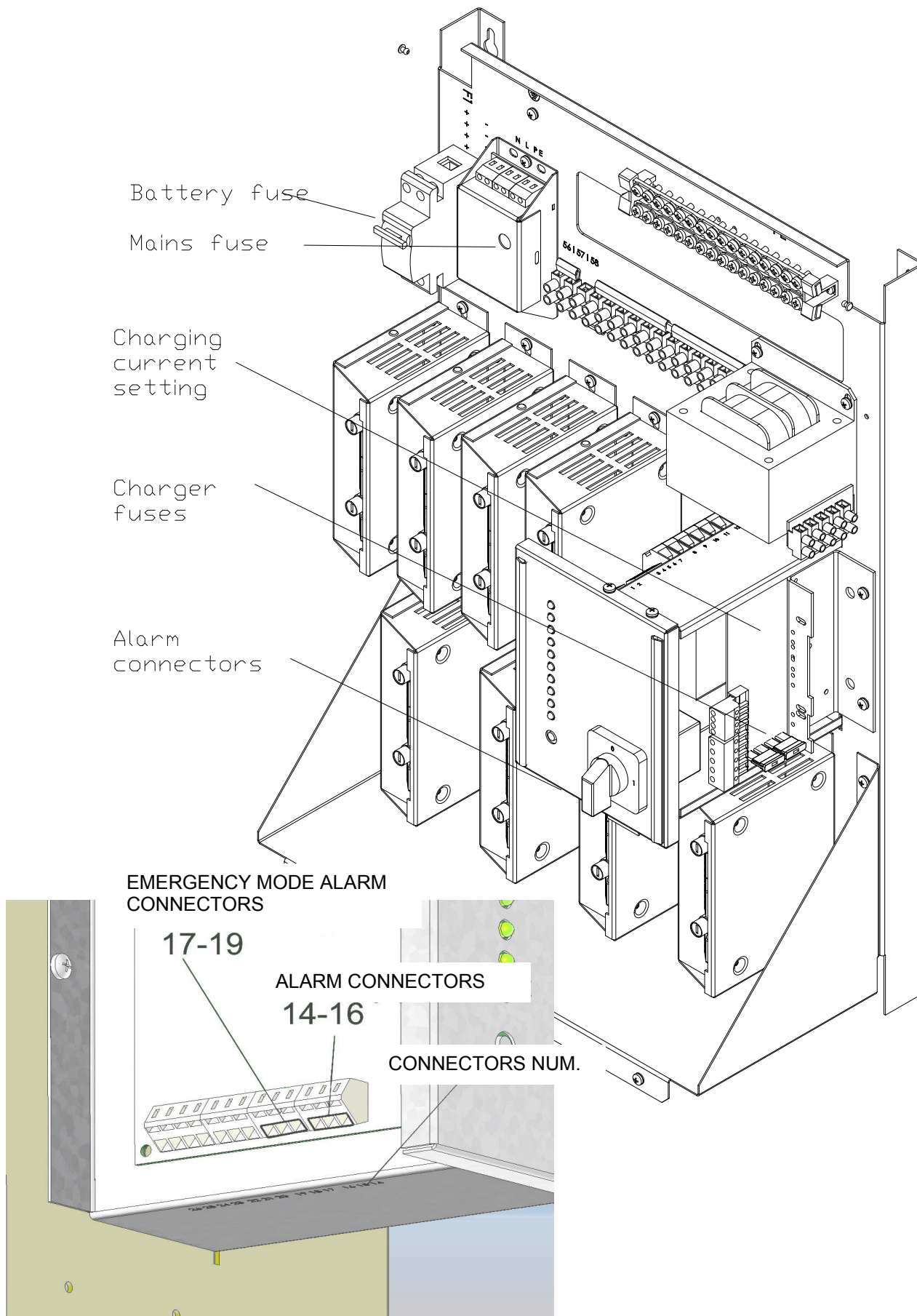

Teknoware Oy, Ilmarisentie 8, FI-15200 LAHTI, FINLAND. Tel. +358 3 883 020, fax +358 3 883 0260
 www.teknoware.fi e-mail: emexit@teknoware.fi

APPENDIX 5

Connections

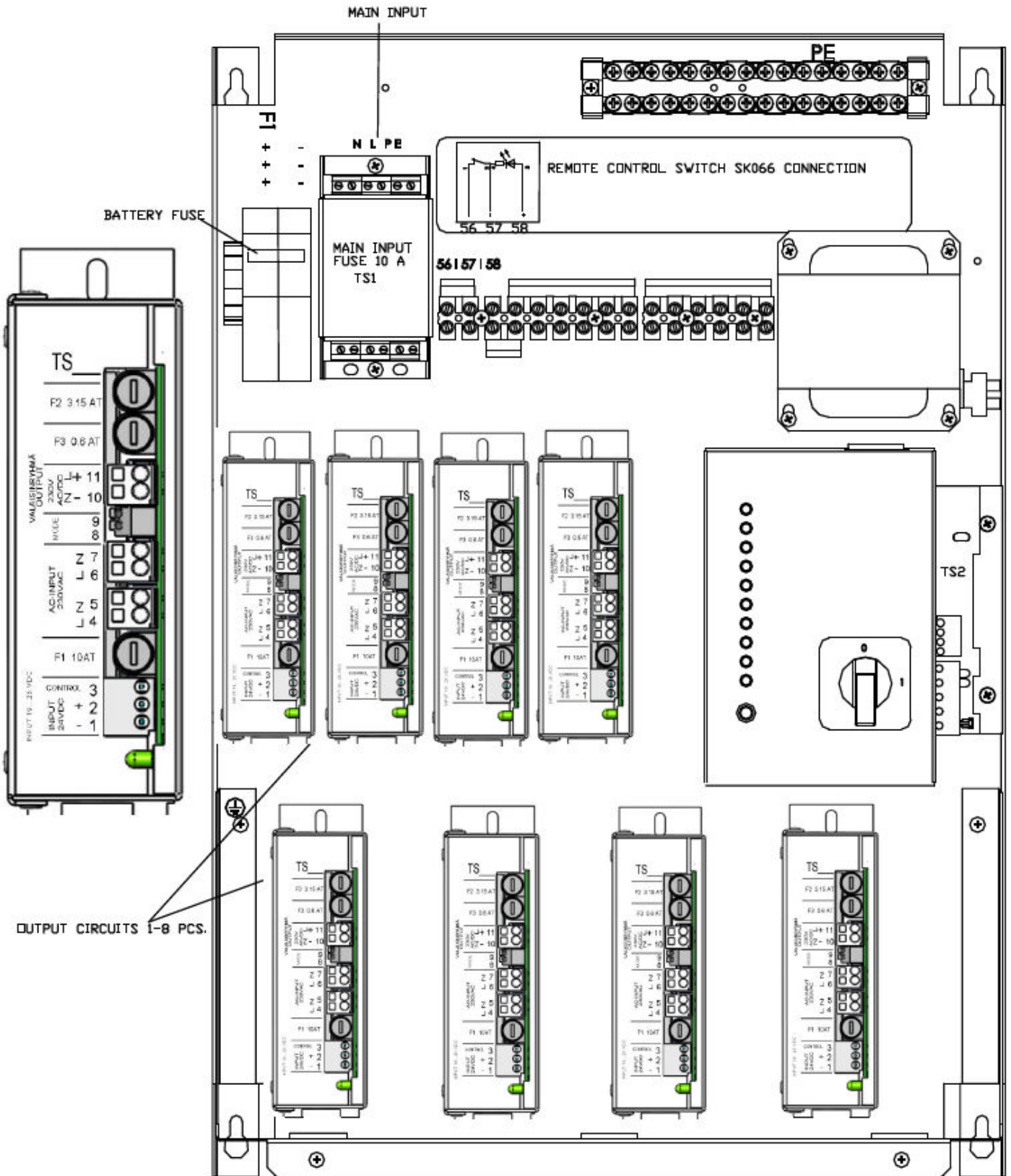

Teknoware Oy, Ilmarisentie 8, FI-15200 LAHTI, FINLAND. Tel. +358 3 883 020, fax +358 3 883 0260
 www.teknoware.fi e-mail: emexit@teknoware.fi

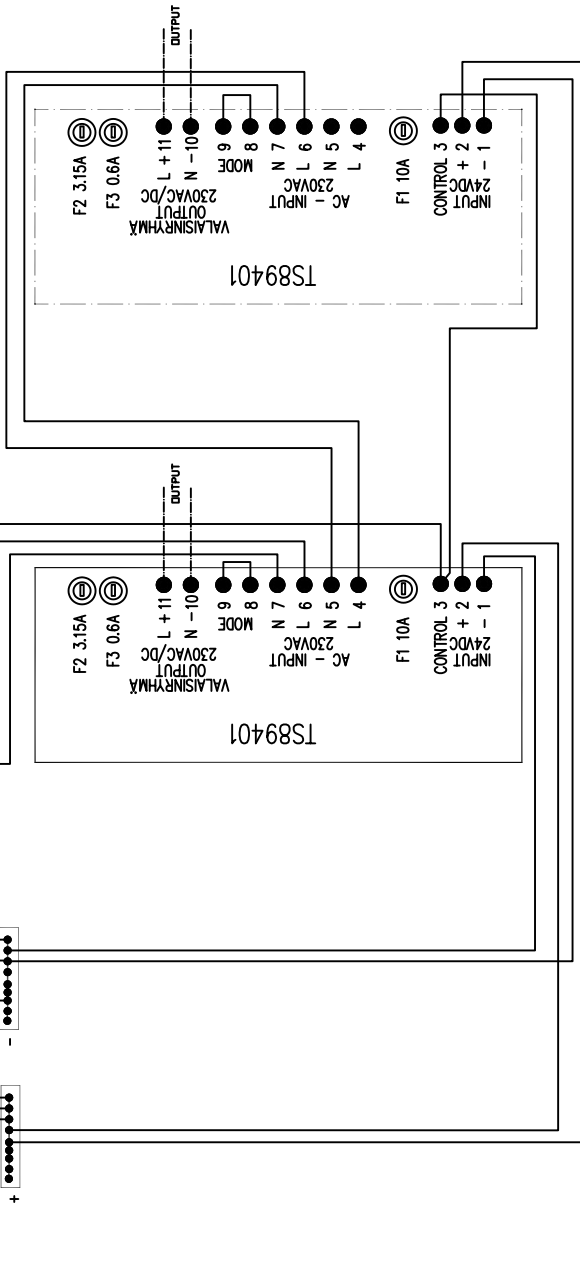
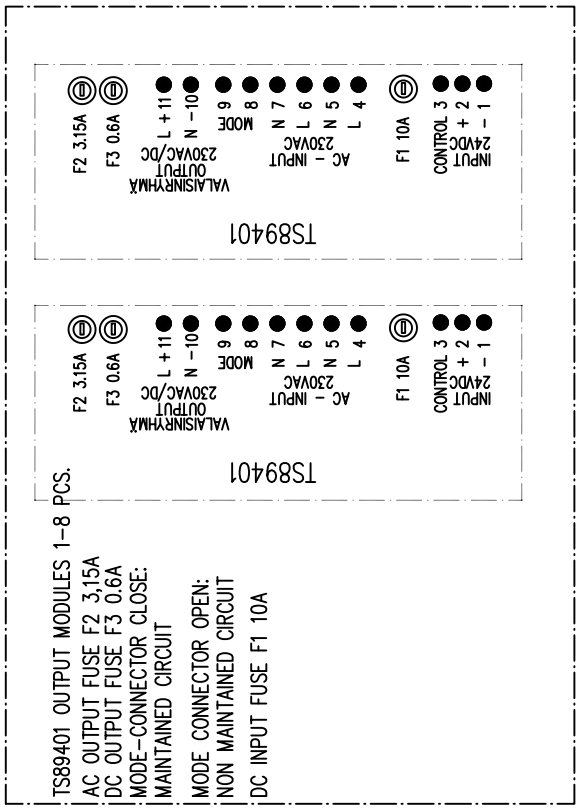
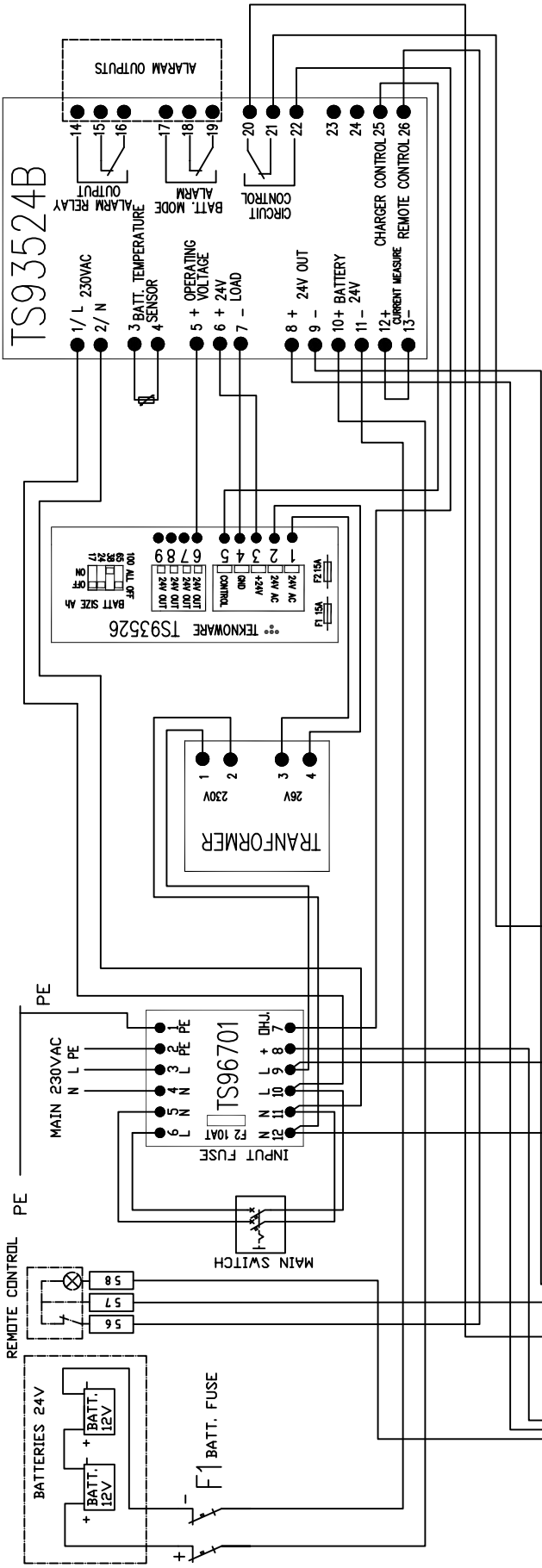

Date	By	Check	App.	Rev	SCALE	Date	Name
20.03.07	PHO			B		12.03.07	PHO
02.01.09	PHO			C			
				D	(A3)		
				E	Old no.		New no.
				F	DRAWING NO.		Rev. Sheet
				G	3F2304		C
				H			2/2

TEKNOWARE®

TK23 TAPSA
CENTRAL BATTERY UNIT
WIRING DIAGRAM

© Added sheet 2

COPYING OF THIS DOCUMENT AND GIVING IT TO OTHERS AND THE USE OR COMMUNICATION OF THE CONTENTS THEREOF ARE FORBIDDEN WITHOUT EXPRESS AUTHORITY. OFFENDERS ARE LIABLE TO THE PAYMENT OF DAMAGES. ALL RIGHTS ARE RESERVED IN THE EVENT OF THE GRANT OF A PATENT OR THE REGISTRATION OF A MODEL OR DESIGN.

Name	Circuit	Cable/mm2	Circuit power Maintained /NM maintained /W	Huom

Output circuits, 230V AC/DC
1..8 circuits
120W/VA circuit

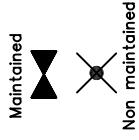

Central Battery Unit Teknoware TK23XX

--- Maintained circuits tot. ___ W
--- Non maintained circuits tot. ___ W
--- Circuits available
Total output tot. ___ W

Batteries... 24 V / ___ Ah / ___ h

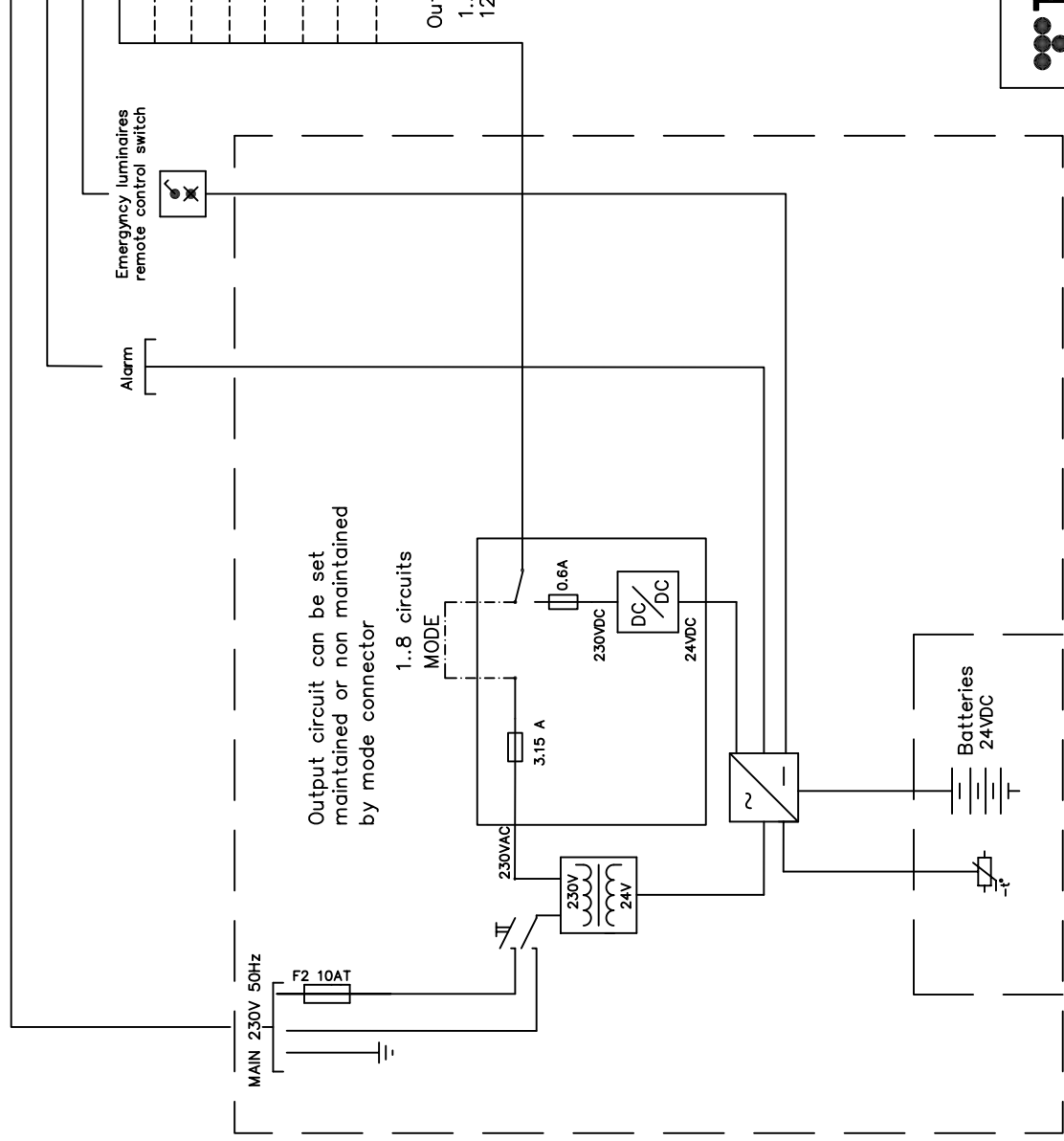

TEKNOWARE®

TK23XX
CENTRAL BATTERY UNIT
MAIN DIAGRAM

Date	By	Check.	App.	Rev	SCALE	Date	Name
20.03.07	PHO			B	SCALE (A4)	21.03.05	PHO
02.01.09	PHO			C		Old no.	
				D			
				E			New no.
				F			
				G	DRAWING NO.		Rev. Sheet
				H	4E23002		C 2/2

COPYING OF THIS DOCUMENT AND GIVING IT TO OTHERS AND THE USE OR COMMUNICATION OF THE CONTENTS THEREOF ARE FORBIDDEN WITHOUT EXPRESS AUTHORITY. OFFENDERS ARE LIABLE TO THE PAYMENT OF DAMAGES. ALL RIGHTS ARE RESERVED IN THE EVENT OF THE GRANT OF A PATENT OR THE REGISTRATION OF A MODEL OR DESIGN.